

## Lifting Column Item No 291

# User Manual

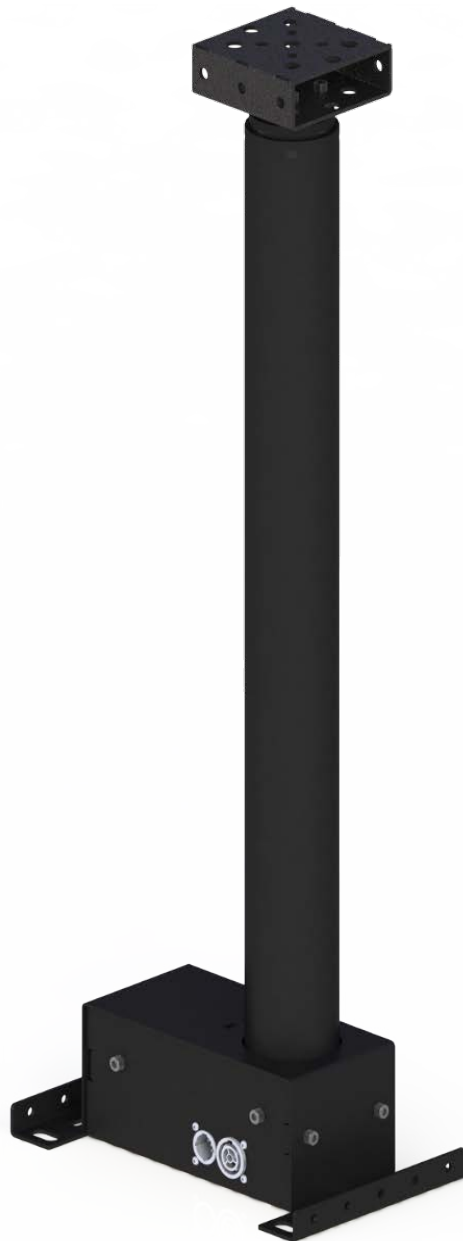

# Safety Information



## WARNING!

**Read the safety precautions in this section before installing, powering, operating or servicing this product.**

The following symbols are used to identify important safety information on the product and in this manual:



**DANGER!**  
Safety hazard.  
Risk of severe injury or death.



**DANGER!**  
Hazardous voltage. Risk of lethal or severe electric shock.



**WARNING!**  
Fire hazard.



**WARNING!**  
Burn hazard. Hot surface. Do not touch.



**WARNING!** Refer to user manual.



This product is for professional use only. It is not for household use. This product presents risks for severe injury or death due to fire hazards, electric shock, and falls.



Read this manual before installing, powering or servicing the lifting column; follow the safety precautions listed below and observe all warnings in this manual and printed on the lifting column. If you have questions about how to operate the lifting column safely, please contact your Wahlberg Motion Design supplier or Wahlberg Motion Design.



### PROTECTION FROM ELECTRIC SHOCK

- Disconnect the lifting column from AC power before removing or installing any cover or part and not when in use.
- Always ground (earth) the lifting column electrically.
- Use only a source of AC power that complies with local building and electrical codes and has both overload and ground-fault (earth-fault) protection.
- Before using the lifting column, check that all power distribution equipment and cables are in perfect condition and rated for the current requirements of all connected devices.
- Power input throughput cables must be rated 20 A minimum, have three conductors 1.5 mm<sup>2</sup> (AWG16) minimum conductor size and an outer cable diameter of 5-15 mm (0.2-0.6 inch). Cables must be hard usage type (SJT or equivalent) and heat-resistant to 90°C (194°F) minimum. In the EU the cables must be <HAR> or equivalent.
- Use only Neutrik powerCON TRUE1 NAC3FX-W cable connectors to connect to power input sockets. Use only Neutrik powerCON TRUE1 NAC3MX-W cable connectors to connect to power throughput sockets.
- Assembly power supply cables following the instructions in this manual only (see page 13).
- Isolate the lifting column from power immediately if the power plug or any seal, cover, cable, or other component is damaged, defective, deformed, wet, or showing signs of overheating. Do not reapply power until repairs have been completed.

- Do not expose the lifting column to rain or moisture.
- Refer any service operation not described in this manual to a qualified technician.

#### PROTECTION FROM BURNS AND FIRE

- Do not operate the lifting column if the ambient temperature (Ta) exceeds 40°C (104°F).
- The exterior of the lifting column becomes warm during use. Avoid contact by persons and materials. Allow the lifting column to cool for at least 10 minutes before handling.
- Do not modify the lifting column in any way not described in this manual.
- Install only genuine Wahlberg parts.

#### PROTECTION FROM INJURY

- Fasten the lifting column securely to a fixed surface, rig, or structure when in use. The lifting column is not portable when installed.
- Ensure that any supporting structure and/or hardware can hold at least 10 times the weight of all the devices including their load.
- If suspending from a rigging structure, fasten the lifting column using the supplied Manfrotto slim coupler and M12 bolt, nut, and washers supplied with the lifting column according to the manual, see page 11.
- Always install the lifting column as described in this manual. If the lifting column is installed in a location where it may cause injury or damage if it falls, install as described in page 11.
- If possible, allow enough clearance beneath the lifting column so it cannot cause any danger to personnel beneath it.
- Check that all external cobbles and rigging hardware are securely fastened.
- Block access below the work area and from a stable platform whenever installing, servicing or moving the lifting column.
- Do not operate the lifting column with missing or damaged covers or shields
- Do not use the lifting column over the head of people
- Do not use the lifting column to lift people or animals.



#### **Before each use**

- Check that the **lifting column** is safely and correctly installed/mounted.
- Inspect the entire **lifting column** for bends, damage and wear, cut cords, corrosion and abuse.
- Ensure that the **load** is correctly attached, and does not exceed the work load limits.
- Check that the weight of the load does not exceed the limits in the manual.

**Warning! Do not use the lifting column if any damage or error is found!**



## Disposing of this product

Wahlberg Motion Design products are supplied in compliance with Directive 2002/96/EC of the European Parliament and of the Council of the European Union on WEEE (Waste Electrical and Electronic Equipment), as amended by Directive 2003/108/EC, where applicable.

Help preserve the environment! Ensure that this product is recycled at the end of its life. Your supplier can give details of local arrangements for the disposal of Wahlberg Motion Design products.

# Index

<b>SAFETY INFORMATION</b>	<b>2</b>
<b>INDEX</b>	<b>3</b>
<b>TECHNICAL SPECIFICATIONS</b>	<b>6</b>
<b>DRAWING</b>	<b>7</b>
<b>INTRODUCTION</b>	<b>8</b>
PACKAGE CONTENT .....	8
DESCRIPTION.....	8
SAFETY FUNCTIONS .....	8
AREA OF USE.....	9
USING FOR THE FIRST TIME .....	9
TRANSPORT .....	10
<b>PHYSICAL INSTALLATION</b>	<b>11</b>
FASTENING THE LIFTING COLUMN TO A FLAT SURFACE .....	11
MOUNTING THE LIFTING COLUMN ON A TRUSS .....	11
MOUNTING THE LOAD .....	12
<b>AC POWER</b>	<b>13</b>
POWER CABLES AND POWER PLUG .....	13
INSTALLING A POWER INPUT CONNECTOR ON A POWER CABLE .....	13
<b>DATA LINK</b>	<b>14</b>
TIPS FOR RELIABLE DATA TRANSMISSION .....	14
CONNECTING THE DMX .....	14
<b>SET UP</b>	<b>15</b>
BLOCK DIAGRAM .....	15
CONNECTIONS .....	15
EMERGENCY STOP .....	16
MODE SETTING .....	16
DMX ADDRESS SETTING .....	18
RESET .....	19
POSITIONING.....	19
DUTY CYCLE.....	20
SYNCHRONIZED MOVEMENTS OF MULTIPLE LIFTING COLUMNS.....	20
<b>SERVICE AND MAINTENANCE</b>	<b>21</b>
PARTS .....	21
MAINTENANCE PLAN.....	22
CHECKLIST .....	22
ON-SITE SERVICE.....	22
POWER DEFECT .....	22
<b>APPENDIX 1</b>	<b>23</b>
<b>APPENDIX 2</b>	<b>24</b>
<b>APPENDIX 3</b>	<b>26</b>
<b>LIFTING COLUMN - CHEAT SHEET</b>	<b>27</b>

# Technical specifications

Model:	Lifting Column
Item no.:	291
Dimensions (L×W×H):	296 × 178 × 812 mm / 11.7 × 7.01 × 32.0 in
Power supply:	100-240 V AC 50-60 Hz
Power consumption:	Max 150 Watt
Power inlet/outlet:	Neutrik powerCON TRUE1 NAC3PX (F/M)
DMX control signal:	DMX 512 1990 + DMX512A / 3 channels used.
DMX connection:	5 pole XLR, In & link
Lifting height:	97 cm (81 - 178 cm) (38.2 in (31.9 - 70.1 in))
Lifting capacity:	
Control panel - down	60 kg. (132.3 lb)
Control panel - sideways	10 kg. (22.0 lb)
Control panel - up	Not recommended!
Lifting speed:	Variable, 0-55 mm/s (0-2.17 in/s)
Minimum load:	None
Noise emission:	~55 dB (max measured noise at 1 m/3.3 ft.)
Weight:	12 kg (26.5 lb)
Motor:	24 V DC

# Drawing

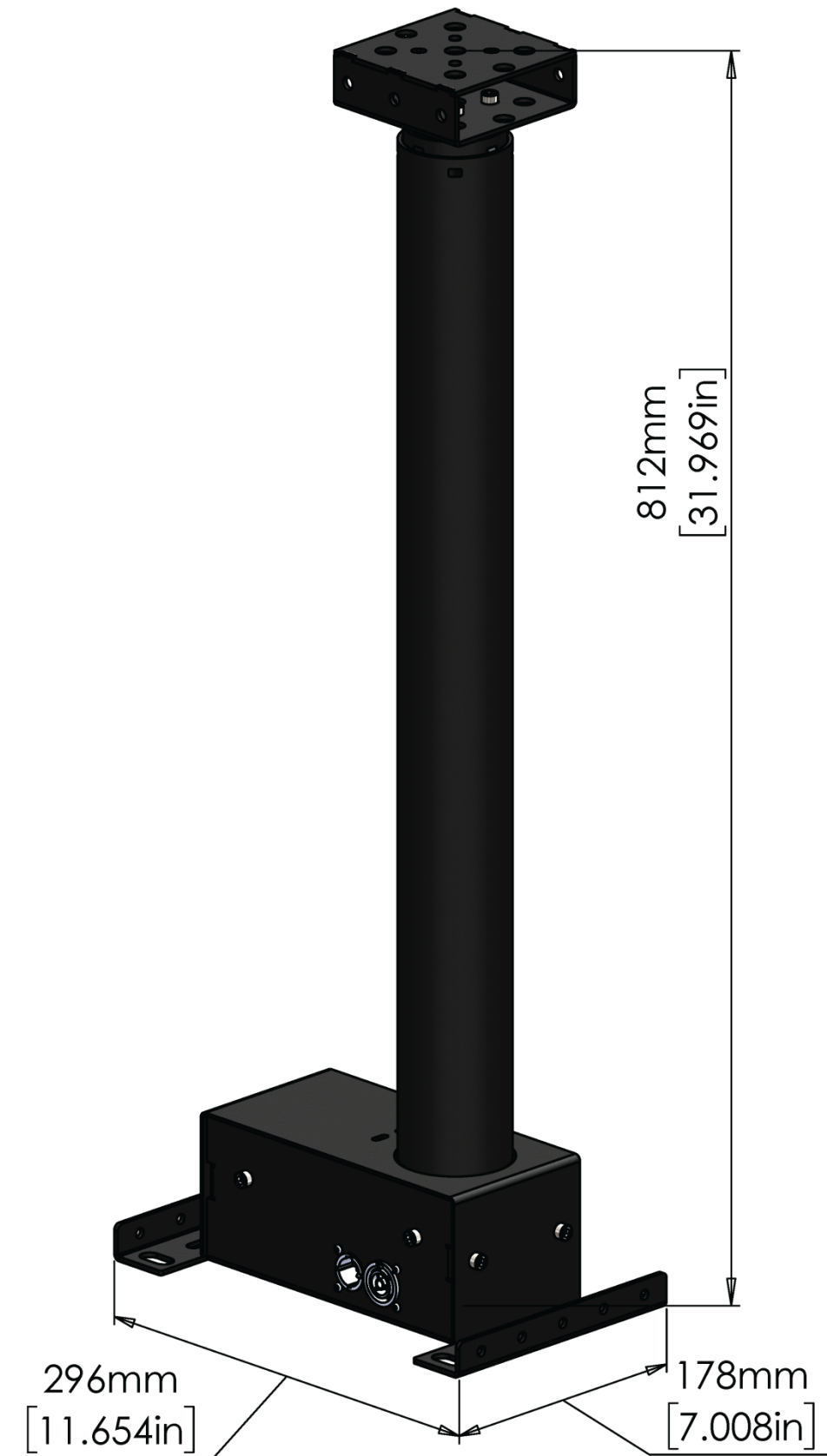

More detailed drawings and from more angles can be found in Appendix 1 on page 23.

# Introduction

Thank you for selecting the Lifting Column, a DMX controlled lifting column from Wahlberg Motion Design. Before using the lifting column for the first time, please read this manual carefully. Failure in handling can cause injury of persons and/or damage the lifting column.

## Package content

- 1× Lifting Column
- 1× Neutrik PowerCon NAC3FX-W female plug for power cable
- 1x User manual
- 1x Cheat sheet

## Description

Lifting Column is a small lifting column for stage use, mainly for use in theatres, shows, and concerts. It lifts props and small set pieces in and out of the stage sphere at a maximum load of 60 kg up and down. Lifting height is 97 cm, and the lifting speed is from 0 mm/s to 55 mm/s.

The lifting column is controlled by the standard DMX controlling signal, so a normal lighting desk can be used to control the movement, programmed as normal light.

For a low number of lifting columns, a standard lighting desk can be used, but when many lifting columns are used, more advanced desks should be used to maintain easy control of the units.

The Lifting Column uses 3 channels of the DMX-line, and they control the position, speed, limits, and reset functions.

The Lifting Column has an advanced internal positioning system with 16 bit, used for finding the position desired by the operator. With a 16 bit positioning channel (ch1 and ch2) the operator set the desired position, and the lifting column will run to this position, with the speed applied on the speed channel (ch3).

Multiple lifting columns are easily daisy chained with power in-out and DMX in-Out, allowing to create advanced and dynamic movements with 100's of lifting columns working together in the same installation.

## Safety functions

The control system ensures that the motor only is powered when:

- The control signal is reliable.
- The position and speed control is on.
- The motor position is calculated after which a PID regulator calculates the motor speed and distance.

Lifting Column should only be operated by an experienced DMX-controlled-lighting-desk-operator.

The lighting desk has to be programmed according to the manual, so the lifting column will stop when the speed is put to 0 %. It is also possible for the user to stop the lifting column by disconnecting it from the main. After power failure the start position of the lifting column needs to be reset before the lifting column can function again.



## Area of use



For indoor use only!

Caution! To reduce the risk of electric shock or injury: use indoors only

Caution! To reduce the risk of electric shock, do not expose to rain: store indoors!

The lifting column is intended for indoor use only. It is designed for lifting and lowering material at the weight and speed stated in "Technical specifications" on page 6. Any other use of the lifting column may result in a risk of injury of persons or equipment damage.

Exceeding the load rating may cause failure of the equipment.

Use only approved rigging connectors to secure the load.

Do not modify the lifting column. For any modification of your lifting column, contact Wahlberg.

It is the customer's sole responsibility to comply with any relevant local laws, regulatory requirements, and restrictions, concerning the use of the lifting column.

## Using for the first time



Important! The Lifting Column must be protected from environmental factors such as physical shocks and vibration during storage.

Warning! Read "Safety Information" on page 2 before installing, powering, operating, or servicing the lifting column. Before applying power to the lifting column:

- Check the Wahlberg Motion Design website at [www.wahlberg.dk](http://www.wahlberg.dk) for the most recent documentation and technical information about the Lifting Column. Wahlberg user manual revisions are identified by the revision number in the bottom of each page.
- Carefully review the "Safety Instructions" on page 2.
- Check that the local AC mains power source is within the lifting column power voltage and frequency ranges.
- See "Power cables and power plug" on page 2. Install a Neutrik powerCON TRUE1 NAC3FX-W power input connector on a suitable power cable. If using the power from a mains power outlet, install a suitable power plug on the power cable.

## Transport



**Important!** The Lifting Column must be protected from environmental factors such as physical shocks and vibration during transportation.

Before transport, it is important to compress the lifting column to reduce risk of damage to the lifting column.

Use only the original packaging, flight case, or pallet frame for protecting the lifting column during transport. Contact Wahlberg for enquiries regarding flight cases or pallet frames.

# Physical installation



**Warning!** The lifting column must be either fastened to a flat surface such as a floor, or clamped to a truss or similar. Do not apply power to the Lifting column if it is not securely fastened.

**Warning!** If fastening the lifting column to a flat surface, the supporting surface must be hard and flat. Fasten the lifting column securely.

**Warning!** If mounting the lifting column on a truss, use only the supplied rigging clamp and M12 bolt. The clamp must be screwed into the central hole in the lifting column's mounting bracket using the supplied M12 washers and M12 locking-nut.

## Fastening the lifting column to a flat surface

The Lifting Column can be fastened to flat surface such as a roof. Check that the surface can support at least 10 times the weight of all lifting columns and equipment to be installed on it.

## Mounting the lifting column on a truss

The Lifting Column can be clamped to a truss or similar rigging structure.

To clamp a Lifting Column to a truss:

1. Check that the rigging clamp is undamaged and that the rigging structure can support at least 10 times the combined weight of all lifting columns and equipment to be installed on it.
2. Use the supplied rigging clamp or contact Wahlberg Motion Design for a replacement.
3. Fasten the clamp to the lifting column with the supplied M12 bolt, nut, and washers in the hole in the mounting clamp of the lifting column.
4. Block access around the work area. Tighten the rigging clamp.



Upright mount

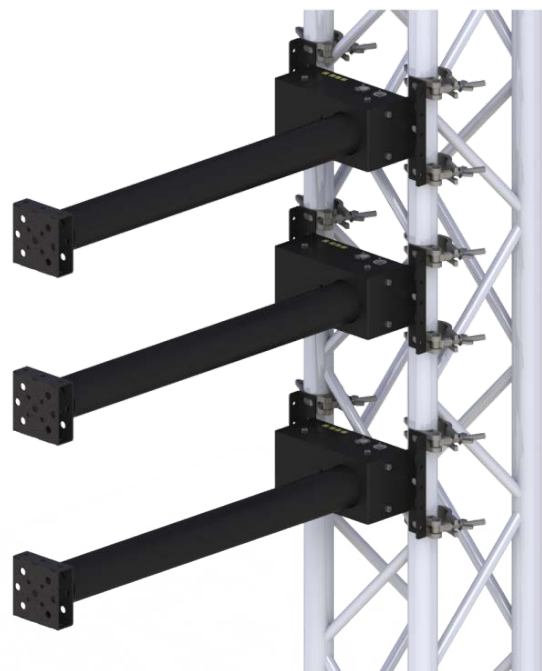

sideways mount

## Mounting the load



**Attention!** The load must be mounted in a way to insure that the load never can run into the lifting column.

The load can be mounted to the mounting plate by the end of the lifting column using bolts and nuts. Ensure that the mounting bolts and nuts have a minimum breaking load of at least ten times the weight of the load.

# AC power



Warning! Read “Safety Information” on page 2 before connecting the lifting column to AC mains power.

Warning! For protection from electric shock, the lifting column must be grounded (earthed). The power distribution circuit must be equipped with a fuse or circuit breaker and ground-fault (earth-fault) protection.

Warning! Socket outlets or external power switches used to supply the lifting column with power must be located near the lifting column and easily accessible so that the lifting column can easily be disconnected from power.

Warning! Check that the voltage range specified on the lifting column’s serial number label matches the local AC mains power voltage before applying power to the lifting column. Do not apply AC mains power to the lifting column at any other voltage than that specified on the lifting column’s serial number label.



## Power cables and power plug

The Lifting Column requires a power input cable with a Neutrik powerCON TRUE1 NAC3FX-W cable connector for AC mains power input. The cable must meet the requirements listed under “Protection from electric shock” on page 2.

Wahlberg Motion Design can supply the PowerCON input connector without a cable.

If you install a power plug on the power cable, install a grounding-type (earthed) plug that is rated 20 A. Follow the plug manufacturer’s instructions. Table 1 shows standard wire color-coding schemes and some possible pin identification schemes; if pins are not clearly identified, or if you have any doubts about proper installation, consult a qualified electrician.

Table 1 - Colour guide

Wire Colour	Conductor	Symbol	Screw (US)
Brown	Live	L	Yellow or brass
Blue	Neutral	N	Silver
Yellow/green	Ground (earth)	 or 	Green

## Installing a power input connector on a power cable

To install a Neutrik powerCON TRUE1 NAC3FX-W input connector on a power Cable, follow the original Neutrik instructions in Appendix 2.

# Data link

A DMX 512 data link is required in order to control the lifting column via DMX. The Lifting Column has 5-pin XLR connectors for DMX data input and output. The pin-out on all connectors is pin 1 = shield, pin 2 = (-), and pin 3 = (+). Pins 4 and 5 in the 5-pin XLR connectors are not used in the Lifting Column but are available for possible additional data signals as required by the DMX512-A standard.

The Lifting Column is subject to the common limit of 32 devices per daisy-chained link. Note that if independent control of a lifting column is required, it must have its own DMX channels. Lifting columns that are required to behave identically can share the same DMX channels. To add more lifting columns or groups of lifting columns when the above limit is reached, add a DMX universe and another daisy-chained link.

## Tips for reliable data transmission

Use shielded twisted-pair cable designed for RS-485 devices: standard microphone cable cannot transmit control data reliably over long runs. AWG24 cable is suitable for runs up to 100 meters (328 ft.).

Never split a DMX line without using an opto-isolated RS-485 splitter/amplifier.

Terminate the link by installing a termination plug in the output socket of the last lifting column. The termination plug, which is a male XLR plug with a 120 Ohm, 0.25 Watt resistor soldered between pins 2 and 3, "soaks up" the control signal so it does not reflect and cause interference. If a splitter is used, terminate each branch of the link.

## Connecting the DMX

To connect the Lifting Column to data:

1. Connect the DMX data output from the DMX controller to the Lifting Column's male 5-pin XLR DMX input connector (DMX 512 IN).
2. Connect the DMX output of the lifting column to the DMX input of the next lifting column and continue connecting lifting columns output to input (DMX 512 OUT).
3. Terminate the last lifting column on the link with a 120 Ohm resistor.

The DMX lamp is the green led, next to the DMX-selectors.

- Glows constantly: DMX connection is correct.
- Flashes: DMX signal is missing or wrongly connected.



# Set up



Warning! Read "Safety Information" on page 2 before installing, powering, operating, or servicing the Lifting Column.

Warning! Only experienced DMX users should operate the lifting column. Contact Wahlberg for further information and education on DMX protocol.

## Block diagram

A block diagram of the control system can be found in Appendix 3.

## Connections

The lifting column has 4 plugs. At the front there are 2 DMX plugs, one for connecting DMX in and one for daisy chaining the DMX connection to other devices. On the back there is a power connection plug for POWER in, and one plug that can be used to daisy chain the power connection between multiple devices.

Front view

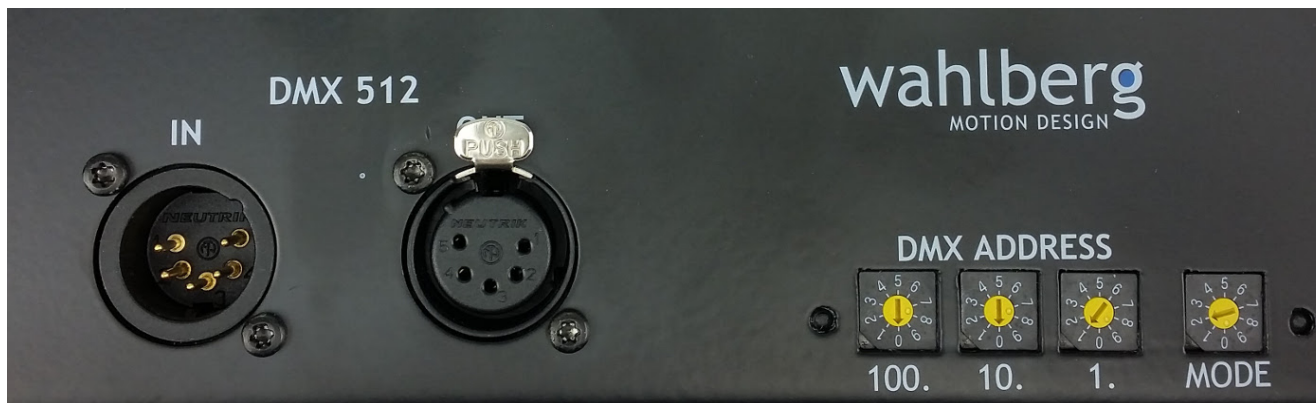

Back view



## Emergency stop

There is no dedicated emergency stop for this lifting column. The lifting column is controlled from a lighting desk, where it should always be set up with a button that sets the speed of the lifting column in operation to 0%.

Normally lighting desks have a "blackout" button that sets all signals to 0% and this will also cause the lifting column to stop.

## MODE setting

The MODE setting allows you to operate the lifting column in different ways. Each MODE setting has a given function. Each mode gives an opportunity for different operational settings of the lifting column. The MODE is selected using the MODE selector on the Lifting column.



The lifting column needs to be reset, before the positioning MODE is possible. The lifting column can be reset manually or automatically. The lifting column must be reset each time its power supply has been disconnected.



**Warning!** Only operate the lifting column when there is a clear view to the lifting column and area beneath it.

**Warning!** Before running the lifting column, ensure that the area beneath the lifting column is cleared to avoid risk of injury.



MODE	Function	Description	Note
1	Positioning mode Slow speed change (Ramp) with auto reset	Positioning mode with slow ramp  After power cycle, the lifting column automatically resets when the speed is > 0 (DMX channel 3)  The position of the lifting column can then be controlled by DMX channel 1,2, and 3	
2	Positioning mode Medium speed change (Ramp) with auto reset	Positioning mode with medium ramp  After power cycle, the lifting column automatically resets when the speed is > 0 (DMX channel 3)  The position of the lifting column can then be controlled by DMX channel 1,2, and 3	
3	Positioning mode Fast speed change (Ramp) with auto reset	Positioning mode with fast ramp  After power cycle, the lifting column automatically resets when the speed is > 0 (DMX channel 3)  The position of the lifting column can then be controlled by DMX channel 1,2, and 3	
0,4,5,6,7,8,9	No function assigned	The lifting column stops	

Table 2 - Overview of MODE functions

## DMX ADDRESS setting

The DMX address, also known as the start channel, is the first channel used to receive instructions from the controller. For independent control, each lifting column must be assigned its own control channels.

The DMX address is configured using the three DMX ADDRESS selectors on the lifting column. The selected DMX address states from which channels, on the lighting desk, the lifting column is controlled. The DMX address can be selected from 1 - 509. The Lifting Column uses 3 DMX channels.



DMX channel	Function	Description
1	Position rough	<p>This channel controls the position of the lifting column, with the speed (DMX channel 3).</p> <p>This rough position works together with the fine position (DMX channel 2).</p> <p>The rough position and the fine position are multiplied in to a 16 bit channel. The rough position is the <i>MSB</i>.</p>
2	Position fine	<p>This channel controls the position of the lifting column, with the speed set on DMX channel 3.</p> <p>This fine position works together with the rough position (DMX channel 1).</p> <p>The fine position and the rough position are multiplied in to a 16 bit channel. The fine position is the <i>LSB</i>.</p>
3	Speed	<p>This channel controls the speed and defines the maximum speed of the lifting column.</p> <p>The lifting column runs with the set max speed, but slows down as closing in on the wanted position.</p> <p>This channel also works as a main brake; the motor does not run unless the channel is set above 0%.</p> <p>The speed-channel can also be used to make soft and slow movements or fast and sudden movements.</p>

Table 3 - Overview of DMX addresses

## Reset

When the lifting column is securely mounted and ready for use it needs to be reset. After power up, the lifting column automatically resets by moving down and find the 0% position at the bottom. The automatic reset is activated when the speed (DMX channel 3) is first set to 0% and then set to 1-100%. The lifting column will move with the same speed regardless of the value of channel 3 as long as it is above 0%. When it is 0% it stops. If the value of channel 3 is set to a value above 0% when the lifting column is power up, it must be set to 0% shortly before the reset will begin. When the bottom position is found the lifting column is ready for use, and can be controlled with DMX channel 1, 2, and 3.

The green LED next to the MODE selector indicates, by fast flashing, that the lifting column needs to be reset, before it can be used

## Positioning

When the lifting column has been reset and the top-position is set, it is possible to use it for positioning run.

The green LED next to the MODE selector indicates by

- Fast flashing                      The lifting column needs to be reset, before it can be used.
- Slow flashing                     The lifting column's load is moving towards the set position
- Steady light                        The set position has been reached and the motor has stopped.



The position is set on the DMX channel 1 and 2, which controls the rough-and fine-position. Where 100 % is the TOP limit and 0 % is the BOTTOM limit.

The speed is set on the DMX channel 3, where 100 % is the fastest and 0 % is the slowest.

The lifting column does not run unless the DMX channel 3 is set above zero, and DMX channel 3, therefore also works as a main brake.

## Duty Cycle



**Warning!** Operating the Lifting Column at a duty cycle higher than recommended, **WILL** damage the Lifting Column.

The duty cycle is the fraction of one period where the motor is active. Duty cycle is commonly expressed as a percentage or a ratio. It can be described as a period of time it takes for a system to complete an on-and-off cycle.

Thus, a 10% duty cycle means the system is on 10% of the time but off 90% of the time. The "on time" for a 10% duty cycle is normally connected to a cycle length in minutes. E.g. a max duty cycle of 10% (2 min RUN / 18 min BREAK), means that the motor may not be active more than 2 minutes every 20 minutes or after 2 minute RUN the motor must have a BREAK for 18 minutes.

The lifting column **MUST NOT** be operated at a duty cycle higher than the values given below:

Load	Speed	Max duty cycle	On time / by off time
10 kg	100%	25%	(minimum 6 min BREAK after 2 min RUN)
30 kg	100%	20%	(minimum 8 min BREAK after 2 min RUN)
60 kg	100%	10%	(minimum 18 min BREAK after 2 min RUN)
10 kg	50%	30%	(minimum 5 min BREAK after 2 min RUN)
30 kg	50%	25%	(minimum 6 min BREAK after 2 min RUN)
60 kg	50%	10%	(minimum 18 min BREAK after 2 min RUN)

## Synchronized movements of multiple lifting columns

If several lifting columns are installed to perform synchronized movements the best result is achieved by using a fading 16 bit position. The lifting columns have a slight deviation in performance of the motors, so some motors have a slightly higher maximum speed than others.

This difference in speed can be solved by running the lifting columns with fading positions, like when fading conventional light over time, the position of the lifting column should be faded from one position to another over a certain amount of time. In that way the lifting columns will follow the fade-curve, and multiple lifting columns can follow the same fade curve.

When fading the positions:

1. The speed channel should be set to 100 to gain the highest possible speed.
2. The position channel should be assigned as a 16 bit channel with *MSB* and *LSB*.
3. The speed of the fade needs to be slower than the maximum speed, so the motors have speed enough to follow the fade-curve.

If the fade of the positions is too fast, the lifting columns will move at the maximum speed, and you will see the difference in the motor speed.

If the fade is too slow the lifting columns will move - stop - move - stop, when the position changes, thus giving a discontinuous movement.

# Service and maintenance



Warning! Read "Safety Information" on page 2 before servicing the Lifting Column.

Warning! Disconnect the Lifting column from AC mains power and allow cooling down for at least 10 minutes before handling.



Warning! Refer any service operation not described in this user manual to a qualified service technician.

Attention! Interval of inspections should be determined according to the frequency of use and the working scenario of the lifting column.



Attention! Signs of malfunction or poor operation should always lead to an inspection of the lifting column, and the lifting column should be taken out of operation until the error is eliminated.

## Parts

Only parts ordered at or approved by Wahlberg should be used in the lifting column to ensure product function and stability. Contact Wahlberg to inquire about spare parts.

## Maintenance plan

The results of all the regular inspections are to be documented and kept available at the company. The written result of the last inspection must be kept available at the site of operation, e.g. by an inspection sticker on the lifting column showing the date of the inspection, the basis of the inspection and the name of the inspector.

### Before every use and weekly

Every time when rigging the lifting column, before running the lifting column - and at least every week when the lifting column is in use:

- Check that the lifting column is safely and correctly installed/mounted
- Check that the lifting column's load and LEDs are visible from the operating station
- Check the entire length of the lifting column for bends, corrosion, and other damages.
- Check that the load is securely mounted

### Monthly

At regular intervals - but at least every month when the lifting column is in use:

- Check the mounting clamp for damages and proper fastening.
- Check that the lifting column is running smoothly.
- Check the secure fastening of the attached equipment.
- Change damaged parts according to this manual.
- Clean dust and dirt on the outside of the system. The cleaners and disinfectants must not be highly alkaline or acidic (pH value 6-8).
- Inspect the connections, cables, and plugs and check for correct functioning

### Yearly

The lifting column has to be inspected by a specialist every 12 months.

### Every 48 months

The lifting column should be inspected by an authorised expert every 48 months.

## Checklist

Use the checklist accordingly; before each use, each month etc.

Check	Type	Result
Installed / mounted correct	Inspection	
Load and LEDs visible for the operator	Inspection	
Load mounted safely	Inspection	
damage and breaks	Inspection	

## On-site service

On-site service and maintenance can be provided by the Wahlberg Motion Design, giving owners access to Wahlberg Motion Design's expertise and product knowledge in a partnership that will ensure the highest level of performance throughout the product's lifetime. Please contact Wahlberg Motion Design for details.

## Power defect

If the lifting column does not react when the power is connected check the following:

- Check that the power plug is properly connected, both to the POWER IN plug on the lifting column and to the main power plug.

# Appendix 1

**FRONT VIEW**  
MAX EXTRUSION

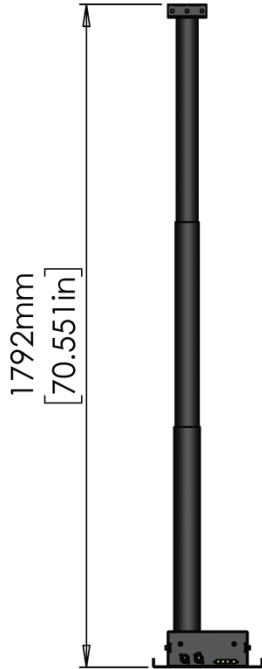

**BACK VIEW**  
MIN EXTRUSION

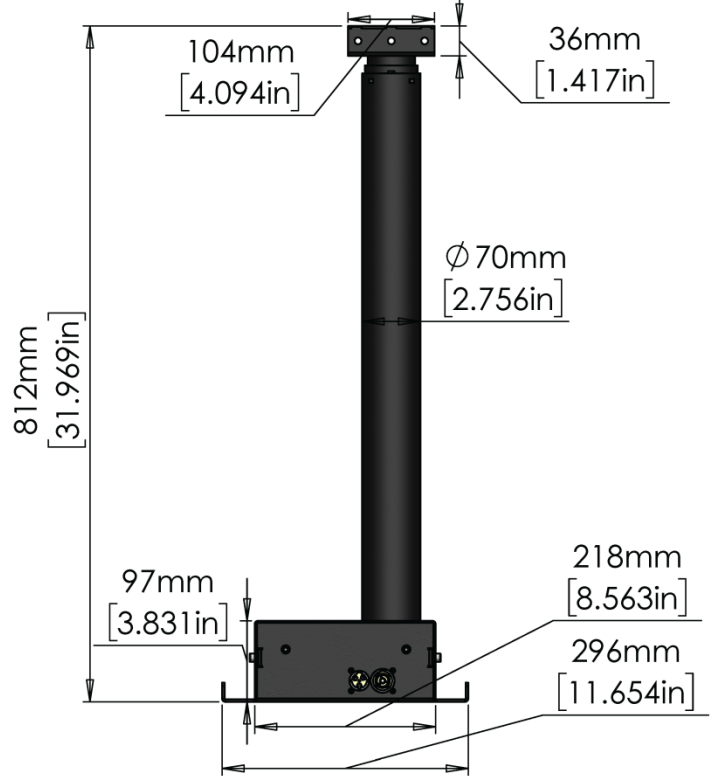

**TOP VIEW**

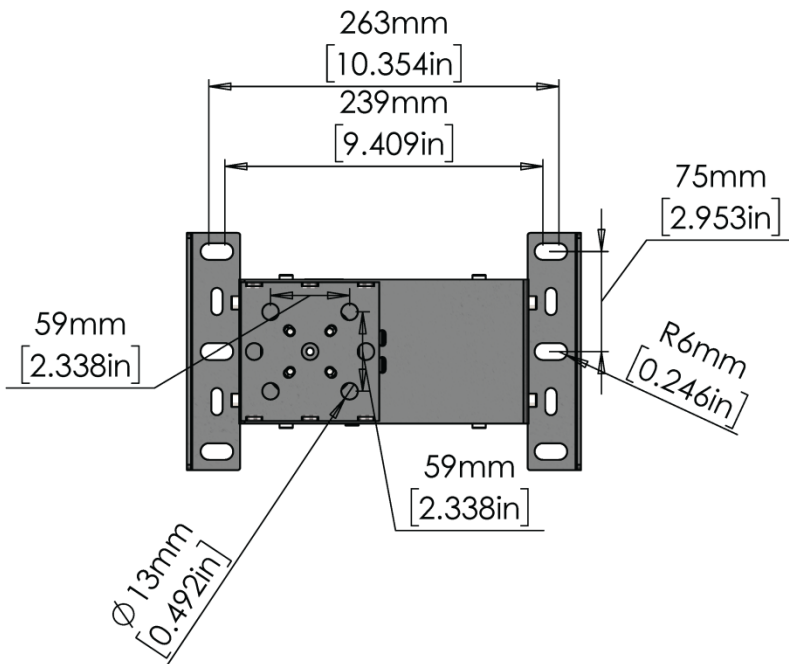

**SIDE VIEW**

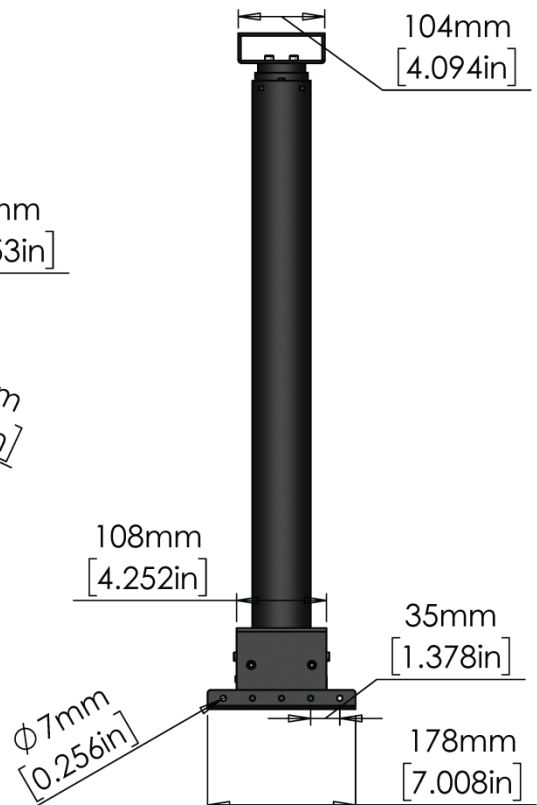

# Appendix 2



## OPERATING & ASSEMBLY INSTRUCTION NAC3FX-W | powerCON TRUE1

### A. OPERATING INSTRUCTION

#### Application:

The powerCON TRUE1 system is certified as connector with breaking capacity according IEC 60320, VDE 0625. It is intended for use as appliance couplers and interconnection couplers. It serves to supply power to an appliance and from an appliance to another equipment. To be installed by qualified person only.

#### Connector Assignment:

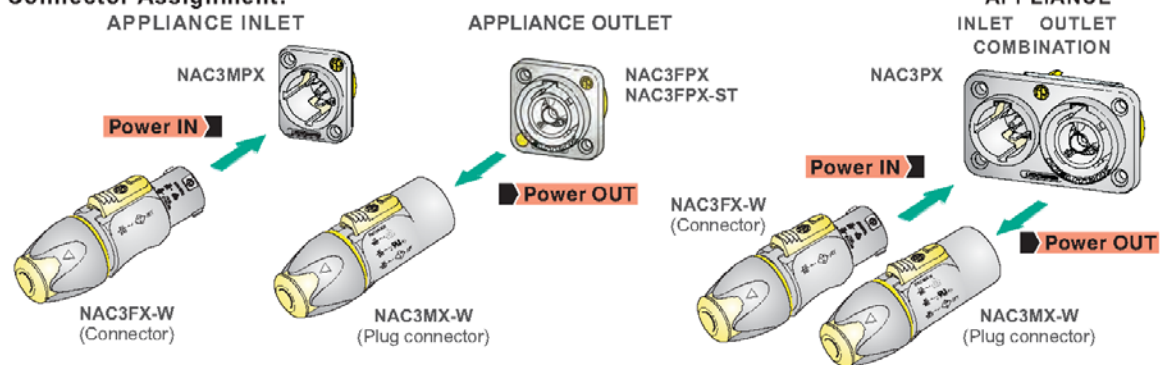

<b>Approval based:</b>	<b>VDE</b> EN 60320-1/EN60320-2-2	✓	<b>UL</b> UL 498 / CSA C22.2 No. 182.3	✓
<b>Rating:</b>	250 V ac / 16 A		250 V ac / 20 A	
<b>Cable Type:</b>	H05VV-F3G 1.0 mm <sup>2</sup> , Length max. 2 m H05VV-F3G 1.5 - 2.5 mm <sup>2</sup> H07RN-F3G 1.5 mm <sup>2</sup>		SJTOW, SJOOW 3 x 12 AWG	
<b>Strain Relief:</b>	White chuck		White chuck	
<b>Cable O.D.:</b>	6.0 - 12.0 mm		6.0 - 12.0 mm	

### B. ASSEMBLY INSTRUCTION

- A** Insert cable into the bushing and housing.

**Note:** "Apply cable pulling lubricant to cable jacket."

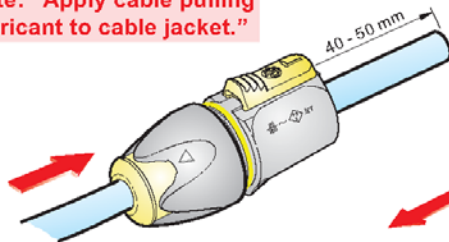

- B** Separate the housing from the bushing (cable remain in bushing)

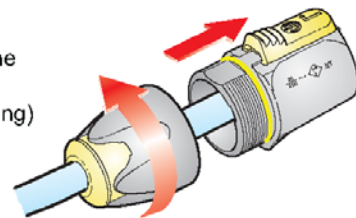

- C** Place chuck over the cable.

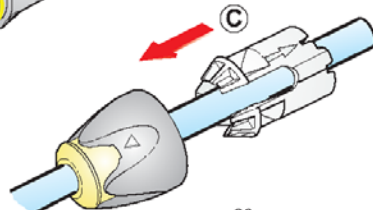

- D** Prepare cable as shown.

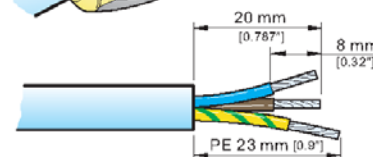

VDE (EN 60320-1/EN60320-2-2)

- i Recommendation:**  
Wire Pulling Lubricant - LUB-I/0.95 from 3M™

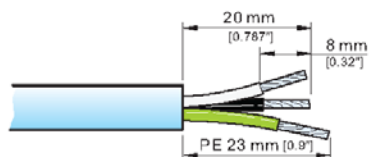

UL (UL 498 / CSA C22.2 No. 182.3)



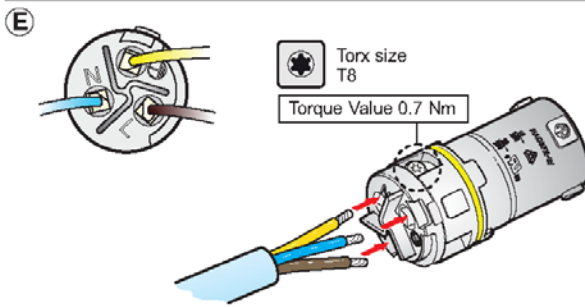

Slide the cable into the contacts and clamp with the screw with Torx size T8.

Wiring	VDE	UL
L →	brown	black
N →	blue	white
⏚ →	green/yellow	green

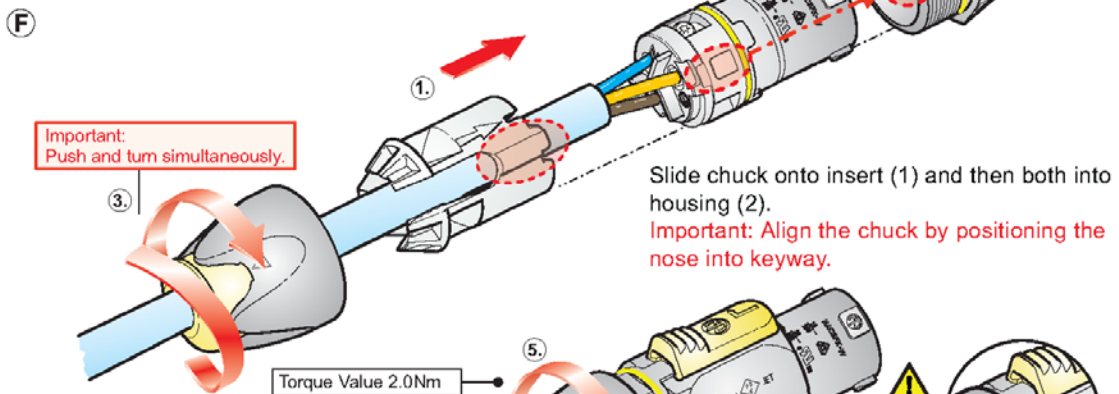

Slide chuck onto insert (1) and then both into housing (2).  
Important: Align the chuck by positioning the nose into keyway.

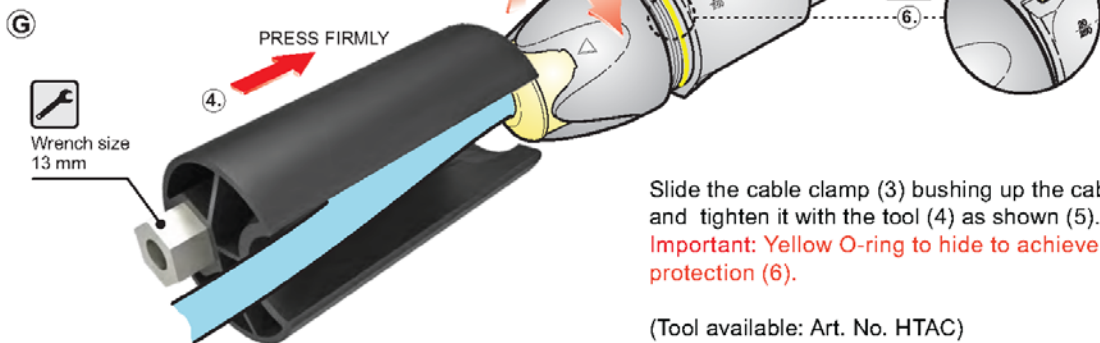

Slide the cable clamp (3) bushing up the cable and tighten it with the tool (4) as shown (5).  
Important: Yellow O-ring to hide to achieve IP protection (6).

(Tool available: Art. No. HTAC)

**FOR DISASSEMBLY - OPEN TWIST LOCK!**

- Press with screw driver to unlock
- Turn bushing 360°.
- Repeat step ①+② until bushing is unscrewed.

**CAUTION**

To ensure protection category, do not expose the connection to bending forces (e.g. do not attach loads to the cable, no free-dangling cable windings etc.).

**SAFETY WARNING**

For safety and certification reasons the connector must be replaced in case of any broken parts or serious damage.

NEUTRIK AG	LI	T: +423/237 24 24	F: +423/232 53 93	NEUTRIK France	FR	T: +33 1/4131 6750	F: +33 1/4131 0511
NEUTRIK USA Inc.	USA	T: +1 704/972 3050	F: +1 704/438 9202	NEUTRIK Tokyo Ltd.	JP	T: +81 3/3663 4733	F: +81 3/3663 4796
NEUTRIK (UK) Ltd.	UK	T: +44 1983/811 441	F: +44 1983/811 439	NEUTRIK Hong Kong Ltd.	HK	T: +852/2687 6055	F: +852/2687 6052
NEUTRIK Vertriebs GmbH	DE/NL/AT/DK	T: +49 8131/280 890	F: +49 8131/280 830	NEUTRIK India Pvt. Ltd.	IND	T: +91/982 05 43 424	F: +91/22 26163 540

Draft, Nr.: BDA 378 | Update: 09.06.2017 | Data subject to change without prior notice. ©2017 NEUTRIK®. ALL RIGHTS RESERVED. NEUTRIK® and powerCON® is a registered trademark.

# Appendix 3

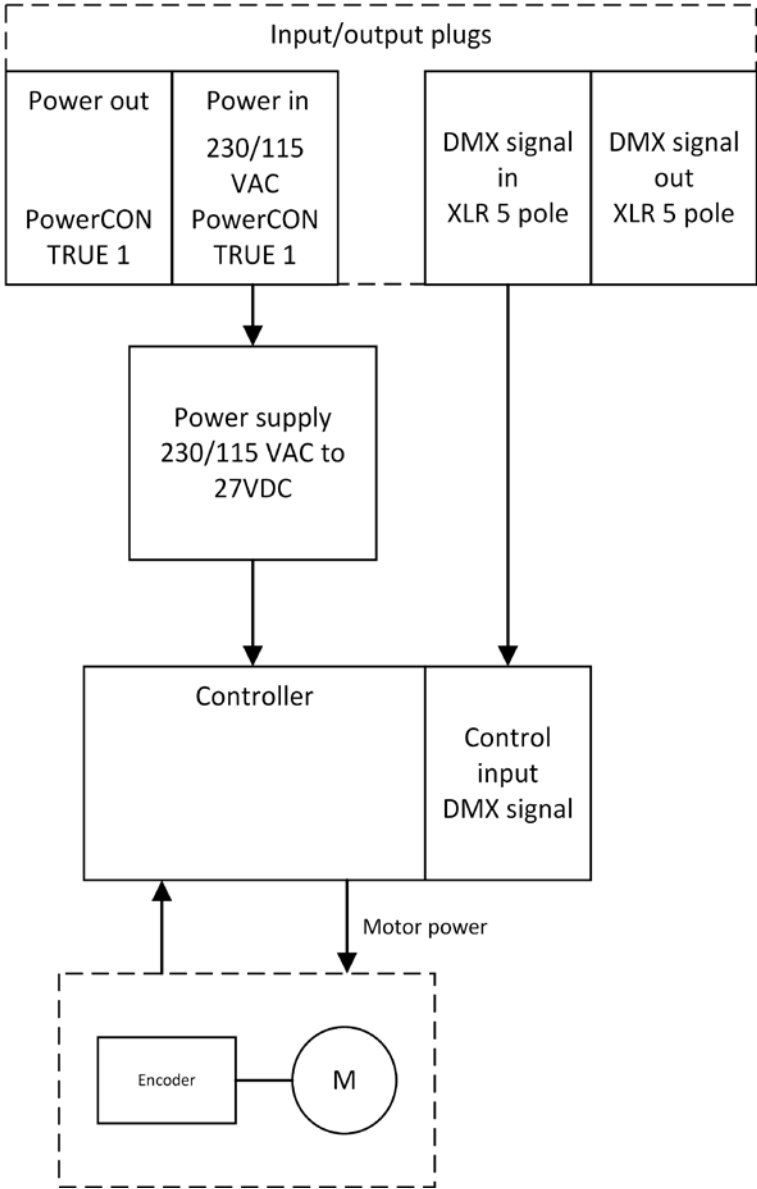

Block diagram of the control system of the lifting column.

[This page is intentionally left blank]

MODE	Functions	DMX channels	Function
0	Neutral function – motor stops	1	Position rough (Hi of a 16 bit DMX channel)
1	Positioning with slow ramp	2	Position fine (Lo of a 16 bit DMX channel)
2	Positioning with medium ramp	3	Set the maximum speed
3	Positioning with fast ramp		
4,5,6,7,8,9	Neutral function – motor stops		

## How to get started

1. Mount the Lifting Column according to the instructions in the user manual.
2. Set the DMX address using the 100, 10, and 1 switches. Set MODE to 1
3. Apply DMX from a Lighting desk, best is a desk with manual faders.
4. Make sure that your six channels are patched from DMX channel 1 to 3.
5. Pull all channels on to 0%
6. Apply power to the Lifting Column - DMX lamp should be lit, and MODE lamp flashing.
7. Set DMX channel 3 to 50% - The Lifting Column will slowly move down till it reaches the hard **BOTTOM** limit.  
This must be done each time the Lifting Column is power cycled.
8. Set channel 1 to 25 % - The Lifting Column will move up till it reaches 25% of the total travel length.
9. Set channel 1 to 75 % - The Lifting Column will move up till it reaches 75% of the total travel length.



### Before each use

- Check that the **lifting column** is safely and correctly installed/mounted.
- Inspect the entire **lifting column** for bends, damage and wear, cut cords, corrosion and abuse.
- Ensure that the **load** is correctly attached, and does not exceed the work load limits.
- Check that the weight of the load does not exceed the limits in the manual.

**Warning! Do not use the lifting column if any damage or error is found!**